

EXTERNAL ROTOR MOTOR FAN

160mm

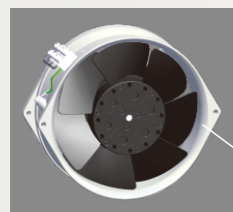

1 White Shell

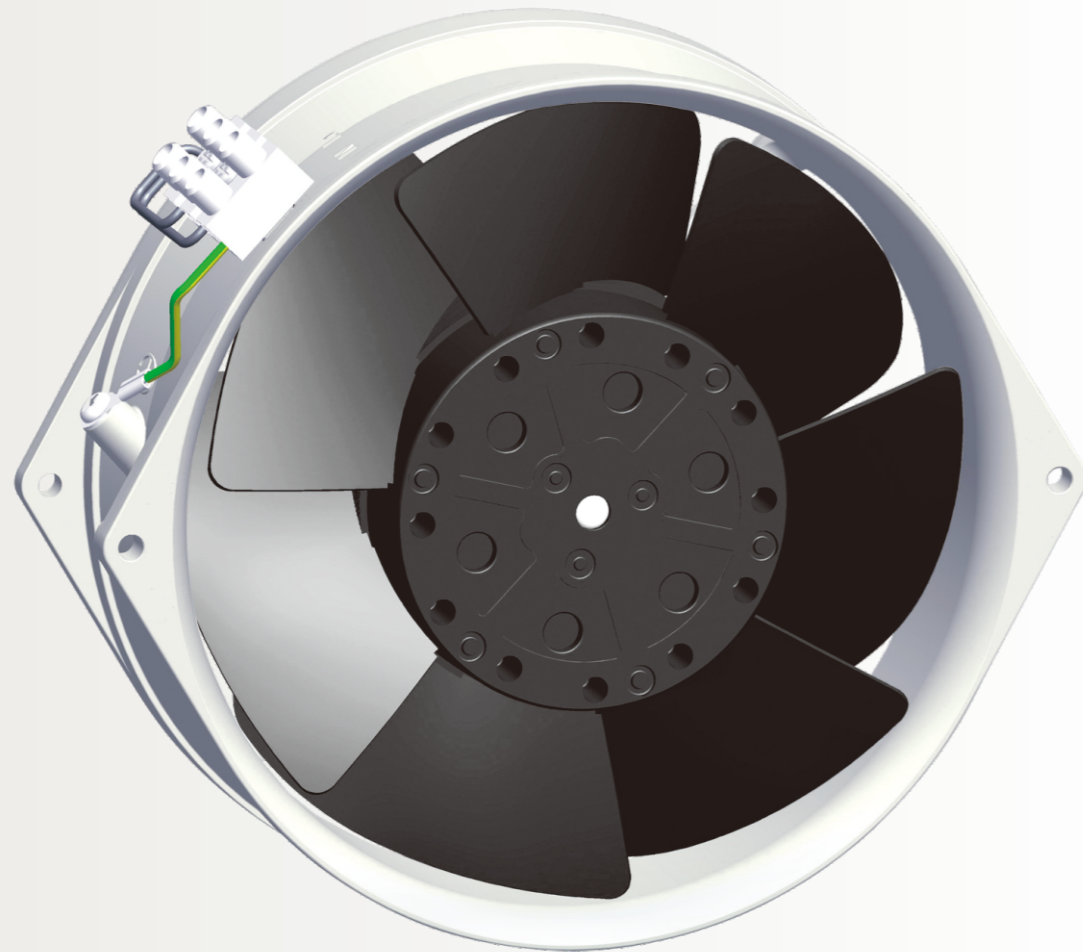
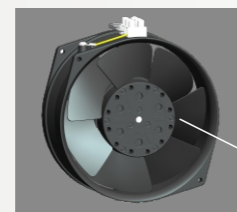

2 Black Shell

- 1 **Frame**
Aluminum die-casting, surface is finished by anti-corrosion treatment with primary color or black electrophoresis anti-corrosion treatment
- 2 **Impeller**
Metal impellers are welded to motor rotor, and surface is finished by black electrophoresis anti-corrosion treatment
- 3 **Operation Temperature/Humidity**
Temperature -40°C ~ +80°C Humidity 0% ~ 95%
- 4 **Protection**
Motor Internal with automatic recovery thermal protector
- 5 **Withstand Voltage**
AC 1,800V , 1 min at 0.5mA, 50/60 Hz
- 6 **Insulation System**
design according to IEC61858 Grade F,
- 7 **Protection Grade** IP44

- 1
- 2
- 3 / -40 ~ +80 0% ~ 95%
- 4 :
- 5 AC 1800V <10mA 50/60Hz 1
- 6 IEC61858 F
- 7 IP 44

FJ16052MABD

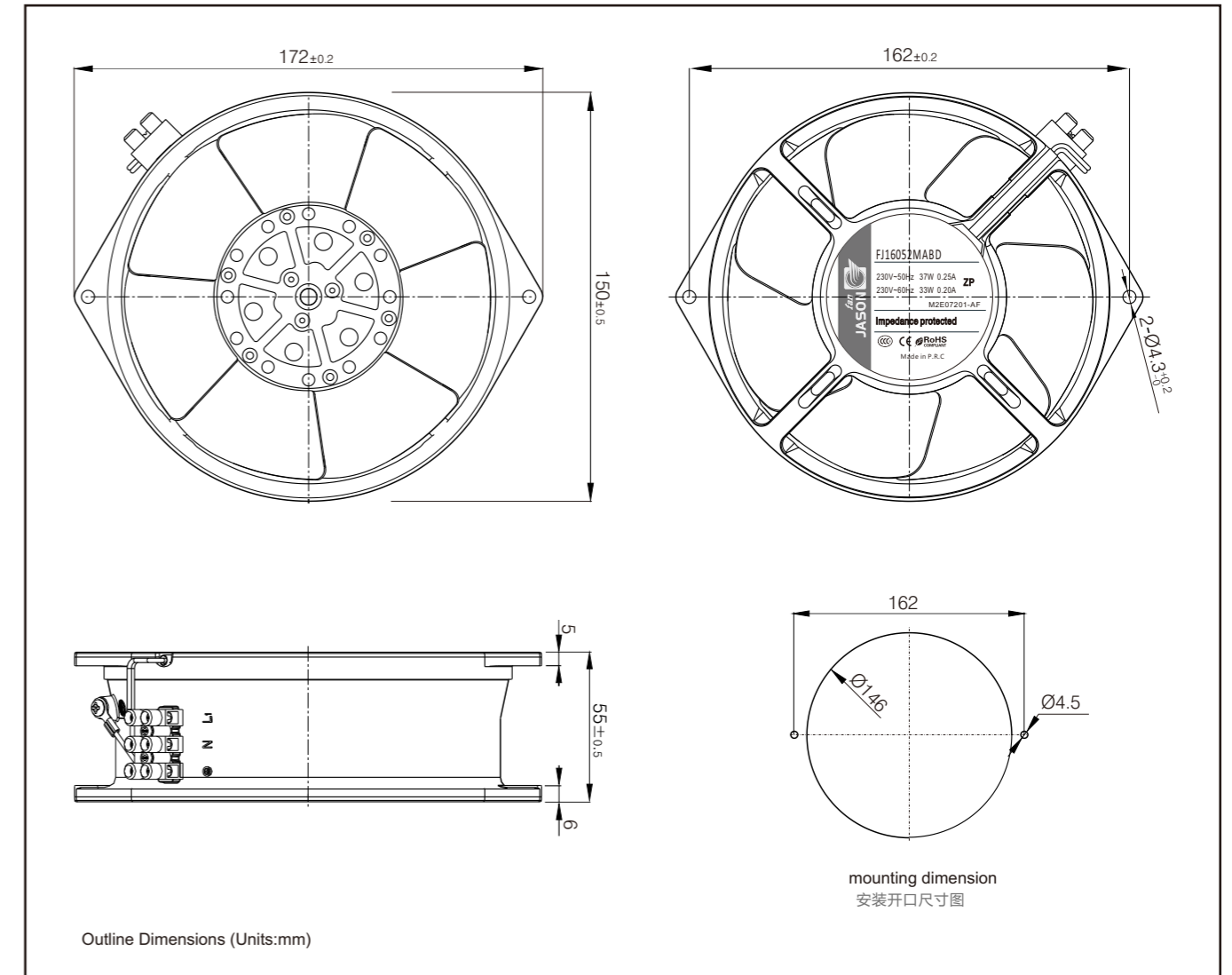

- A Rotation direction of blades : CCW seen from the front impellers
- B Power Connection: PA-10 terminal connection
- C Unit weight: 1.1kg

- A PA-10
- B 1.1kg
- C

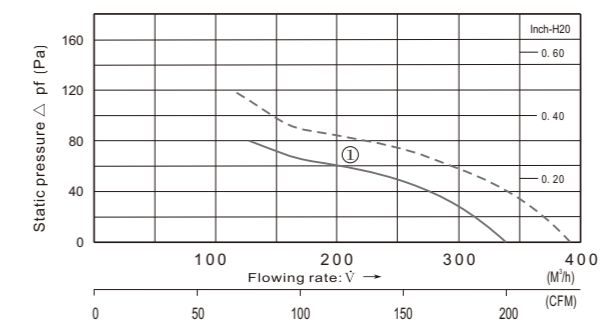

Parameters

Type	Motor	Rated Voltage	Frequency	current	Power	Speed	Max Air Flow	Static Pressure	Noise	Curve	Capacitor
		V	Hz	(A)	(W) _{10% 25%}	(min-1)	CFM m3/h	(Pa)	(dB)		(μ F)
FJ16051MABD	M2S7201-AF	115	50	0.49	37	2650	189 320	80	49	①	-----
			60	0.41	34	3000	224 380	120	53		
FJ16052MABD	M2E7201-AF	230	50	0.25	37	2650	189 320	80	49		
			60	0.20	33	3000	224 380	120	53		
FJ16053MABD	M2D7201-AF	380	50	0.14	37	2650	189 320	80	49		
			60	0.12	34	3000	224 380	120	53		